

- Option metal or thermoplastic enclosure
- Changeover circuit with rating 15A
- Internal "MV" Series miniature switch
- Choice of 1 or 2 internal switches
- Snap action contacts mechanism
- Long mechanical life
- Quick connect (faston)/solder terminals
- Rubber feet against sliding
- Double insulated  (thermoplastic model)
- Metal protection cover, optional

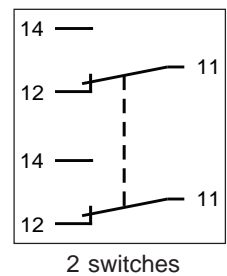

Circuitry

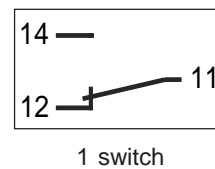

Specifications

Electrical Rating	15A 250Vac		
Contact Resistance	50 mΩ maximum initial (at 1A 5Vdc)		
Ambient Temperature	+85°C maximum		
Mechanical Life Expectancy	10.000.000 cycles		
Electrical Life Expectancy	50.000 cycles		
Degree of Protection	Metal :	IP40 (EN 60529)	
	Plastic :	IP43 (EN 60529)	
Materials	Enclosure: Metal:	Painted Steel	
		Plastic:	Thermoplastic
	Protection Cover:	Painted Steel	

Dimensions

Dimensions in mm

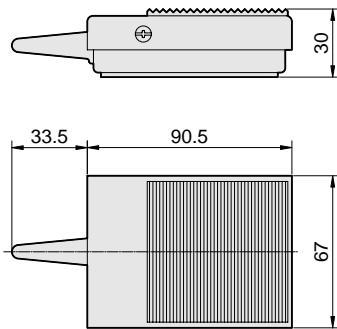

Metal Miniature Foot Switch

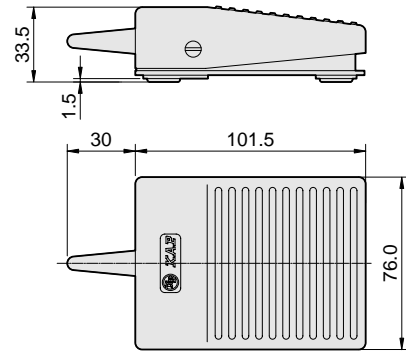

Thermoplastic Miniature Foot Switch

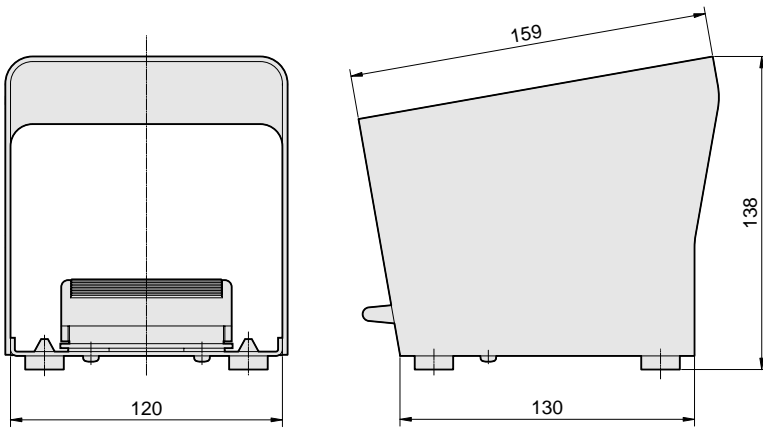

Metal Protection Cover to Thermoplastic or Metal Miniature Foot Switch



Sujeito a alteração sem informação prévia

Ordering Information

SP1PCC

Series

Protection Cover

without Protection = none ①

with Protection = C

Internal Switches

1 Switch = 1 ①

2 Switches = 2 ②

Enclosure

Metalic = none

Thermoplastic = PC ①

Replacement Switch
MV7ACA1



Special Applications

The products presented in this catalog are models of regular commercial use, however we are able to develop "personalized" models for special applications.

Contact us.

Note:

① Standard versions. The others (not marked) upon request.

② Is not guaranteed the simultaneous operation of the 2 switches